



Summit⁴⁸ and²⁴

The Summit48 and Summit24 provide 10/100 Mbps aggregation in service provider data centers, server farms, metropolitan area networks, multi-tenant buildings, and wiring closets. They integrate seamlessly into networks while delivering high port density, wire-speed performance and low cost of ownership.

Summit48 With 48 switched 10/100 Mbps auto-negotiating Ethernet ports and two full-duplex GBIC-based 1000BASE-SX, LX or LX-70 Gigabit Ethernet ports, Summit48 has a 17.5 Gbps non-blocking switch fabric and a forwarding rate of 10.1 million packets per second. Summit48 comes with wire-speed Layer 2 and wire-speed basic Layer 3 switching using static routing or RIP V1/V2 routing protocols. For easy scalability, the Summit48 upgrades to full Layer 3 switching with a simple upgrade key. The full Layer 3 switching includes support for protocols such as OSPF, DVMRP, PIM and IPX routing of multiple encapsulation types.

Summit24 With 24 switched 10/100 Mbps auto-negotiating Ethernet ports and one full-duplex GBIC-based 1000BASE-SX, LX or LX-70 Gigabit Ethernet port, Summit24 has an 8.5 Gbps non-blocking switch fabric and a forwarding rate of 5.1 million packets per second. Summit24 comes with wire-speed Layer 2 and wire-speed basic Layer 3 switching using static routing or RIP V1/V2 routing protocols. For easy scalability, the Summit24 upgrades to full Layer 3 switching with a simple upgrade key. The full Layer 3 switching includes support for protocols such as OSPF, DVMRP, PIM and IPX routing of multiple encapsulation types.

Pre-installed on every Extreme Networks switch, the ExtremeWare™ software suite combines industry-standard protocols to ensure interoperability with legacy switches and routers, plus Policy-Based Quality of Service (QoS) for bandwidth management and traffic.

- **Gigabit Ethernet links to the network core and high-density 10/100 Mbps ports to the edge**
- **Non-blocking switch fabric bandwidth with wire-speed switch performance**
- **Start with basic Layer 3 switching and wire-speed Layer 2 switching**
- **Scale up to full Layer 3— using advanced IP Routing Protocols and IPX Routing— with a simple upgrade key**
- **Policy-Based QoS, including bandwidth management, prioritization and congestion control**
- **Fault-tolerant: multiple load-sharing trunks, multiple spanning trees and optional redundant power supply**
- **Extensive management through HTTP, SNMP, RMON and command line interface**



Summit⁴⁸ and²⁴

Simple to Deploy, Easy to Manage

The high-density 10/100 Mbps auto-negotiating Ethernet ports in these switches simplify deployment and minimize complexity. There's no need to change any existing subnet infrastructures. Both the Summit48 and the Summit24 come equipped with wire-speed Layer 2 switching and wire-speed basic Layer 3 switching that supports static routing and the use of the RIP protocol. Using a system-specific upgrade key, network managers can migrate anytime to full Layer 3 switching including support for protocols such as OSPF, PIM and IPX routing of multiple encapsulation types.

The ExtremeWare standards-based software suite also simplifies switch management. Preloaded on every Summit switch, ExtremeWare includes a comprehensive command line interface (CLI) and the easy-to-use ExtremeWare Vista™ Web-based management interface. ExtremeWare also supports SNMP and four groups of RMON.

A Future-Proof Solution

With Summit48 and Summit24, Extreme has taken the features and performance of a high-end switch, the simplicity and low cost of an edge device, and deployed them in a stackable 3.5 inch-high form factor. Included with this powerful price/performance mix are link aggregation, wire-speed Layer 2 switching, wire-speed basic Layer 3 switching and quality of service—everything a business needs for today's switched networks.

For future proofing, network managers can easily upgrade their switches at any time to include support for protocols such as OSPF, PIM and IPX routing of multiple encapsulation types. As part of Extreme's end-to-end switching solutions, both switches are expected to give businesses the ability to handle most bandwidth-intensive applications in the future.

Maximum Performance and Scalability

The Summit48 and Summit24 maximize performance and scalability for a wide range of 10/100 Mbps connections. They can provide dedicated 10/100 Mbps links to desktops and servers or multiple 10/100 or 1000 Mbps links can be aggregated to load-share traffic. They also support dual load-shared backbone connections.

Like other Summit switches, Summit48 and Summit24 are non-blocking so their backplane capacity is always greater than the aggregation of all their ports. This enables full wire-speed performance on all ports, all the time—even under severe traffic conditions.

Lower Total Cost of Ownership

Low cost is an important factor when considering 10/100 Mbps aggregation. And the combination of low cost, high port density and wire-speed performance make Summit48 and Summit24 the ultimate choice for service provider data centers and wiring closets.

Service Provider Solutions

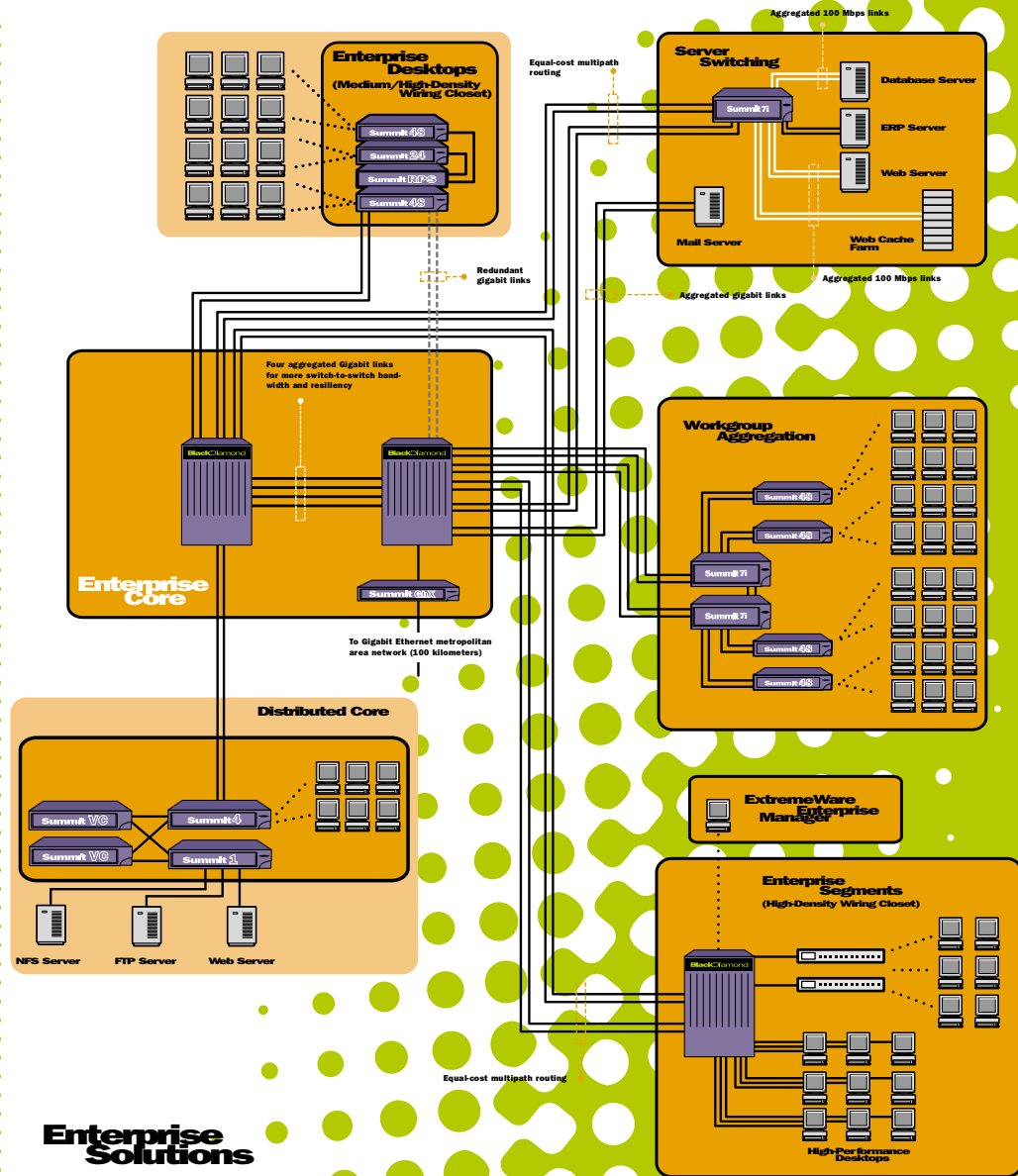
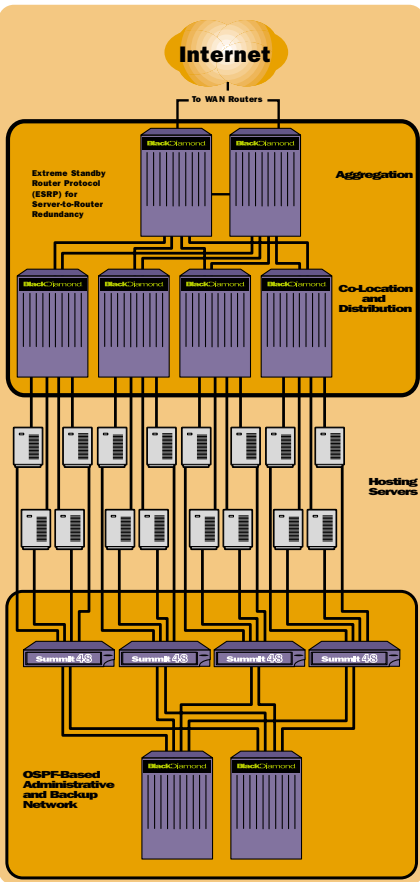

Enterprise Solutions

Summit 48 and 24 Specifications

General

True QoS via ExtremeWare and Policy-Based Quality of Service
 Full or half duplex operation
 Multiple spanning tree support
 Multiple load-sharing trunks
 Up to 128,000 Layer 2 addresses
 Up to 64,000 Layer 3 addresses
 4 MB buffering

Summit48

48 10/100BASE-X ports
 Two GBIC-based 1000BASE-SX ports

Summit24

24 10/100BASE-TX ports
 One GBIC-based active 1000BASE-X ports

Protocols and Standards

IEEE 802.3z 1000BASE-X
 IEEE 802.3ab 1000BASE-T
 IEEE 802.3x Flow control
 IEEE 802.3ad Link aggregation
 IEEE 802.1D-1998 (includes 802.1p)
 IEEE 802.1Q VLAN Tagging
 RFC 768 UDP
 RFC 783 TFTP
 RFC 791 IP
 RFC 792 ICMP
 RFC 826 ARP
 RFC 854 Telnet
 RFC 1058 RIP
 RFC 1122 Host Requirements
 RFC 1256 Router Discover Protocol
 RFC 1519 CIDR
 RFC 1542 BootP
 RFC 1723 RIP v2
 RFC 1812 IP Router Requirement
 RFC 2068 HTTP

RFC 2178 OSPF
 RFC 2131 BootP/DHCP Relay
 RFC 2236
 DVMRP v3
 PIM

Performance

Summit48
 17.5 Gbps non-blocking bandwidth
 Route/filter/forward 10.1 million pps

Summit24

8.5 Gbps non-blocking bandwidth
 Route/filter/forward 5.1 million pps

Management and Security

RFC 1157 SNMP v1/v2c
 RFC 1213 MIB II
 RFC 1354 IP forwarding table MIB
 RFC 1493 Bridge MIB
 RFC 1573 Evolution of Interface
 RFC 1643 Ethernet MIB
 RFC 1724 RIP v2 MIB
 RFC 1757 Four groups of RMON
 RFC 2021 RMON Probe Configuration
 RFC 2037 Entity MIB
 RFC 2138 RADIUS
 RFC 2239 802.3 MAU MIB
 ExtremeWare Enterprise MIB
 HTML and Telnet Management

Physical and Environmental

Dimensions:
Summit48 & Summit24
 (H) 3.5 in x (W) 17.32 in x (D) 17.42 in
 (H) 8.90 cm x (W) 44.0 cm x (D) 44.25 cm

Weight:

Summit48
 18 lbs (8.17 kg)
Summit24
 17 lbs (7.65 kg)

Operating Temperature: 0° C to 40° C
 Storage Temperature: -10° C to 70° C
 Humidity: 10% to 95% non-condensing
 Power: 90-250 VAC, 47-63 Hz, 2.5 A max
 Includes hardware for mounting in a standard 19-inch rack
 Heat Dissipation:
 341-2 BTU/hr (118 Watts)
 MTBF = 50,000 hours

Regulatory Compliance

FCC Part 15 Class A
 ICES-0003 Class A
 VCCI Class 1
 EN55022 Class A
 CISPR 22 Class A
 EN55024

Environmental

EN60068 to Extreme IEC68 schedule

Reliability

Minimum 50000 hrs MTBF to Mil HDBK
 217F Notice I, Parts Stress Method

Acoustic

58 dB/pW Weighted Sound Power Level to
 ENC27779 and EN29295

Summit24 and Summit48 Ordering Information

Order Number	Description
13010	24 10/100BASE-TX ports, 2 unpopulated GBIC based 1000BASE-X port (1 active and 1 redundant) with Basic Layer 3 switching software
13020	24 10/100BASE-TX ports, 2 unpopulated GBIC based 1000BASE-X port (1 active and 1 redundant) with Full Layer 3 switching software
15010	48 10/100BASE-TX ports, 4 unpopulated GBIC based 1000BASE-X port (2 active and 2 redundant) with Basic Layer 3 switching software
15020	48 10/100BASE-TX ports, 4 unpopulated GBIC based 1000BASE-X port (2 active and 2 redundant) with Full Layer 3 switching software
10027	Optional upgrade key from Basic to Full Layer 3 switching software for Summit24
10029	Optional upgrade key from Basic to Full Layer 3 switching software for Summit48
10011	SX GBIC Module (275 meters)
10013	LX GBIC Module (10 kms)
10016	LX-70 GBIC Module (70 kms)
10901	Redundant Power Supply system for Summit24 or Summit48 (supports 2 switches)



For more product information from Extreme Networks, please call 1-888-257-3000.3585 Monroe Street Santa Clara, CA 95051-1450 Phone 408.579.2800 Fax 408.579.3000
 Email info@extremenetworks.com Web www.extremenetworks.com

©2000 Extreme Networks, Inc. All rights reserved. Extreme Networks and BlackDiamond are registered trademarks of Extreme Networks, Inc. in certain jurisdictions. ExtremeWare, ExtremeWare Vista, ExtremeWorks, ExtremeAssist, ExtremeAssist1, ExtremeAssist2, PartnerAssist, Extreme Standby Router Protocol, ESRP, SmartTraps, Summit, Summit1, Summit4, Summit4/FX, Summit7i, Summit24, Summit48, Summit Virtual Chassis, SummitLink, SummitGbX, SummitRPS, Velocity, the BlackDiamond logo and the Extreme Networks logo are trademarks of Extreme Networks, Inc., which may be registered or pending registration in certain jurisdictions. The Extreme Turbodrill logo is a service mark of Extreme Networks, Inc., which may be registered or pending registration in certain jurisdictions. All other registered trademarks, trademarks and service marks are property of their respective owners. Specifications are subject to change without notice. L-DS-548-24-101